



OPERATING INSTRUCTIONS

EN

Translation of the original instructions

TCP 350

Electronic Drive Unit

PFEIFFER  **VACUUM**



Table of contents

| | | |
|----------|--|-----------|
| 1 | About this manual | 5 |
| 1.1 | Validity | 5 |
| 1.2 | Conventions | 5 |
| 1.2.1 | Safety instructions | 5 |
| 1.2.2 | Pictographs | 6 |
| 1.2.3 | Instructions in the text | 6 |
| 1.2.4 | Abbreviations | 6 |
| 2 | Safety | 7 |
| 2.1 | Safety precautions | 7 |
| 2.2 | Proper use | 8 |
| 2.3 | Improper use | 8 |
| 3 | Product description | 9 |
| 3.1 | Product identification | 9 |
| 3.1.1 | Scope of delivery | 9 |
| 3.2 | Function | 9 |
| 3.3 | Range of application | 10 |
| 3.3.1 | Cooling | 10 |
| 3.4 | Connection panel | 10 |
| 4 | Wiring diagrams | 11 |
| 4.1 | TCP 350 with connecting cable and M12 accessories connector | 11 |
| 4.2 | TCP 350 with connecting cable and M8 accessories connector | 12 |
| 4.3 | TCP 350 with connecting cable and RJ45 accessories connector | 13 |
| 5 | Installation | 14 |
| 5.1 | Assembly | 14 |
| 5.1.1 | Rack installation | 14 |
| 5.2 | Connections | 14 |
| 5.3 | Connection "external pump" | 15 |
| 5.4 | Earthing | 16 |
| 5.5 | Accessory connection | 16 |
| 5.6 | Connection "RS-485" | 17 |
| 5.6.1 | Connections | 17 |
| 5.6.2 | Cross-linking via the connection RS-485 | 17 |
| 5.7 | "SERVICE" connection | 18 |
| 5.7.1 | Connections | 18 |
| 5.8 | Connection "REMOTE" | 18 |
| 5.8.1 | Pin assignment | 18 |
| 5.8.2 | +24 V DC* Output / Pin 1 | 19 |
| 5.8.3 | Inputs | 19 |
| 5.8.4 | Outputs | 20 |
| 5.8.5 | Relay contacts | 20 |
| 5.9 | Connecting a measuring device | 21 |
| 5.10 | Connecting to the mains power supply | 21 |
| 6 | The Pfeiffer Vacuum parameter set | 22 |
| 6.1 | General | 22 |
| 6.1.1 | Conventions | 22 |
| 6.2 | Parameter overview | 22 |
| 6.2.1 | Annotation | 22 |
| 6.2.2 | Control commands | 22 |
| 6.2.3 | Status requests | 23 |
| 6.2.4 | Set value settings | 24 |



| | | |
|-----------|---|-----------|
| 7 | Operation | 25 |
| 7.1 | Switching on | 25 |
| 7.1.1 | Self-test | 25 |
| 7.2 | LC-Display | 25 |
| 7.3 | Symbol description | 26 |
| 7.4 | Key functions | 26 |
| 7.5 | Operation | 27 |
| 7.5.1 | Selecting the parameters | 27 |
| 7.5.2 | Set parameters | 27 |
| 7.6 | Configuring the connections | 28 |
| 7.6.1 | DO2 and relay on "REMOTE" | 28 |
| 7.6.2 | Analog output on "REMOTE" | 28 |
| 7.6.3 | Accessory connection | 28 |
| 8 | Operation with the Pfeiffer Vacuum parameter set | 29 |
| 8.1 | General | 29 |
| 8.1.1 | Factory settings | 29 |
| 8.1.2 | Checking the adjustments | 29 |
| 8.1.3 | Keypad lock | 29 |
| 8.2 | Rotation speed set value | 29 |
| 8.3 | Remote control | 30 |
| 8.3.1 | Standard operation | 30 |
| 8.3.2 | REMOTE Priority ON | 30 |
| 8.3.3 | REMOTE Priority OFF | 30 |
| 8.4 | Gas type dependent operations | 30 |
| 8.5 | Run-up time | 31 |
| 8.6 | Adjusting the rotation speed switchpoint | 31 |
| 8.7 | Rotation speed setting mode | 31 |
| 8.8 | Standby | 32 |
| 8.9 | Operation mode backing pump | 32 |
| 8.9.1 | Continuous operation | 32 |
| 8.9.2 | Intermittent operation (diaphragm pumps only) | 32 |
| 8.10 | Operation with accessories | 33 |
| 8.10.1 | Air cooling/heating | 34 |
| 8.10.2 | Vent modes | 34 |
| 8.11 | Pressure measurement | 35 |
| 8.11.1 | Displaying the gauge type | 35 |
| 8.11.2 | Displaying the active pressure value | 35 |
| 8.12 | Monitoring the thermal load | 35 |
| 8.13 | Switching on/off the pump | 36 |
| 8.13.1 | Switching on | 36 |
| 8.13.2 | Switching off | 36 |
| 9 | Pfeiffer Vacuum Protocol for "RS-485" | 37 |
| 9.1 | Telegram frame | 37 |
| 9.2 | Telegrams | 37 |
| 9.2.1 | Example 1 | 37 |
| 9.2.2 | Example 2 | 38 |
| 9.3 | Applied data types | 38 |
| 10 | Malfunctions | 39 |
| 10.1 | General | 39 |
| 10.2 | Operation display via LED | 39 |
| 10.2.1 | Operation display via LED | 39 |
| 10.3 | Error codes | 39 |
| 11 | Accessories | 40 |



- 12 Technical data and dimensions 41**
 - 12.1 Technical data 41
 - 12.2 Dimensions 41
- Declaration of conformity 42**



1 About this manual

1.1 Validity

This operating manual is for customers of Pfeiffer Vacuum. It describes the functioning of the designated product and provides the most important information for safe use of the unit. The description follows applicable EU guidelines. All information provided in this operating manual refers to the current state of the product's development. The documentation remains valid as long as the customer does not make any changes to the product.

Up-to-date operating instructions can also be downloaded from www.pfeiffer-vacuum.com.

1.2 Conventions

1.2.1 Safety instructions

The safety instructions in Pfeiffer Vacuum operating instructions are the result of risk evaluations and hazard analyses and are oriented on international certification standards as specified by UL, CSA, ANSI Z-535, SEMI S1, ISO 3864 and DIN 4844. In this document, the following hazard levels and information are considered:

| |
|--|
| DANGER |
| Imminent danger Indicates an imminent hazardous situation that will result in death or serious injury. |
| WARNING |
| Possibly imminent danger Indicates an imminent hazardous situation that can result in death or serious injury. |
| CAUTION |
| Possibly imminent danger Indicates an imminent hazardous situation that can result in minor or moderate injury. |
| NOTICE |
| Command or note Command to perform an action or information about properties, the disregarding of which may result in damage to the product. |



1.2.2 Pictographs



Prohibition of an action to avoid any risk of accidents, the disregarding of which may result in serious accidents



Warning of a displayed source of danger in connection with operation of the unit or equipment



Command to perform an action or task associated with a source of danger, the disregarding of which may result in serious accidents



Important information about the product or this document

1.2.3 Instructions in the text

→ Work instruction: here you have to do something.

1.2.4 Abbreviations

| | |
|-----------------|---|
| TCP: | Electronic drive unit for turbopump, external with power supply |
| TC: | Electronic drive unit for turbopump |
| DI / DO: | Digital input / digital output |
| AI / AO: | Analog input / analog output |
| [P:000]: | Parameter of the electronic drive unit with number |



2 Safety

2.1 Safety precautions



Duty to inform

Each person involved in the installation or operation of the unit must read and observe the safety-related parts of these operating instructions.

→ The operator is obligated to make operating personnel aware of dangers originating from the unit or the entire system.



WARNING

Danger of unsafe electrical installation

Safe operation after installation is the responsibility of the operator.

→ Do not independently modify or change the pump and electrical equipment.
 → Make sure that the system is integrated in an emergency off safety circuit.
 → Consult Pfeiffer Vacuum for special requirements.



WARNING

Danger of electric shock

In case of defect, the parts connected to the mains supply are under voltage.

→ Always keep the mains connection freely accessible so that you can disconnect it at any time.



WARNING

Automatic start-up after power failure or malfunction acknowledgement

The function "pumping station" of the electronic drive unit remains active after power failure or errors that lead to shut down the pump or the system. The turbopump runs up automatically after power is restored or malfunction acknowledgement.

→ Switch off the function "pumping station" if necessary.
 → Provide safety measures against interference in the high vacuum flange while the turbopump is running.



CAUTION

Automatic start

After bridging the contacts Pin 1, 3, 4 on the connection "REMOTE" and setting up the supply voltage, the turbopump will run up immediately.

→ Switch on the mains supply on the turbopump immediately before operation.

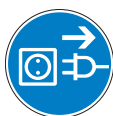

NOTICE

Damages to the pump and drive

Even after the mains power is switched off, the subsequently running pump delivers electric power to the electronic drive unit. There is a danger of electric body contact by premature separating the pump from the electronic drive unit.

→ Never separate the electronic drive unit from the pump when the mains power is connected or the rotor is running.

- Observe all safety and accident prevention regulations.
- Always ensure a safe connection to the protective earthing conductor (PE, protection class I).
- Regularly check the proper observance of all safety measures.
- Before carrying out any work disconnect the unit and all associated installations safely from the mains.
- Do not loosen any plug connection during operations.



- The unit has been accredited with protection class IP 20. Take necessary measures when installing into ambient conditions, which afford other protection classes.
- Use as a desktop unit is only possible with a suitable cover.
- Observe fire protection specifications according IEC 61010 when installing in housings.
- Keep leads and cables well away from hot surfaces ($> 70\text{ }^{\circ}\text{C}$).
- Only separate the pump and the electronic drive unit from each other after disconnecting the supply voltage and the complete standstill of the pump.

2.2 Proper use



NOTICE

EC conformity

The manufacturer's declaration of conformity becomes invalid if the operator modifies the original product or installs additional components.

→ Following installation into a plant and before commissioning, the operator must check the entire system for compliance with the valid EU directives and reassess it accordingly.

- The external electronic drive units TCP 350 are used exclusively for operating HiPace® and CompactTurbo series Pfeiffer Vacuum turbopumps with a capacity of $\leq 800\text{ l/s}$.
- The external electronic drive unit TCP 350 serves as voltage supply, control and monitoring of a turbopump and connected peripherals.
- Only operate the pump with the respective electronic drive unit. The use of other than the intended electronic drive units is not permitted.

2.3 Improper use

Improper use will cause all claims for liability and warranties to be forfeited. Improper use is defined as usage for purposes deviating from those mentioned above, especially:

- connection to pumps or units which are not suitable for this purpose according to their operating instructions
- connection to units which have exposed voltage-carrying parts
- connection to mains supplies, which do not confirm to the regulations IEC 61010 or IEC 60950
- operation of the devices in areas with ionizing radiation



3 Product description

3.1 Product identification

- The external electronic drive unit TCP 350 serves as voltage supply, control and monitoring of a turbopump and connected peripherals.
- For total pressure measurement the connection of a vacuum gauge is possible.

| Characteristics | TCP 350 |
|--------------------------------------|-------------------------------------|
| Connection panel | Standard |
| HiPace turbopump, suitable for TCP | 80, 300, 400, 700, 800 |
| Mains requirement: frequency (range) | 50/60 Hz |
| Mains requirement: voltage (range) | 100-120/200-240 ($\pm 10\%$) V AC |
| Current consumption max. | 4 A |
| Max. power consumption | 420 VA |
| Mains requirement: internal fuse | 5 A, slow blow |

To correctly identify the product when communicating with Pfeiffer Vacuum, always have the information from the rating plate available.



Fig. 1: Example for a rating plate

3.1.1 Scope of delivery

- TCP 350, external electronic drive unit for turbopumps
- Mating plug for the connection "REMOTE" on the TCP 350 (type dependent)
- Fixing materials
- Operating instructions

3.2 Function

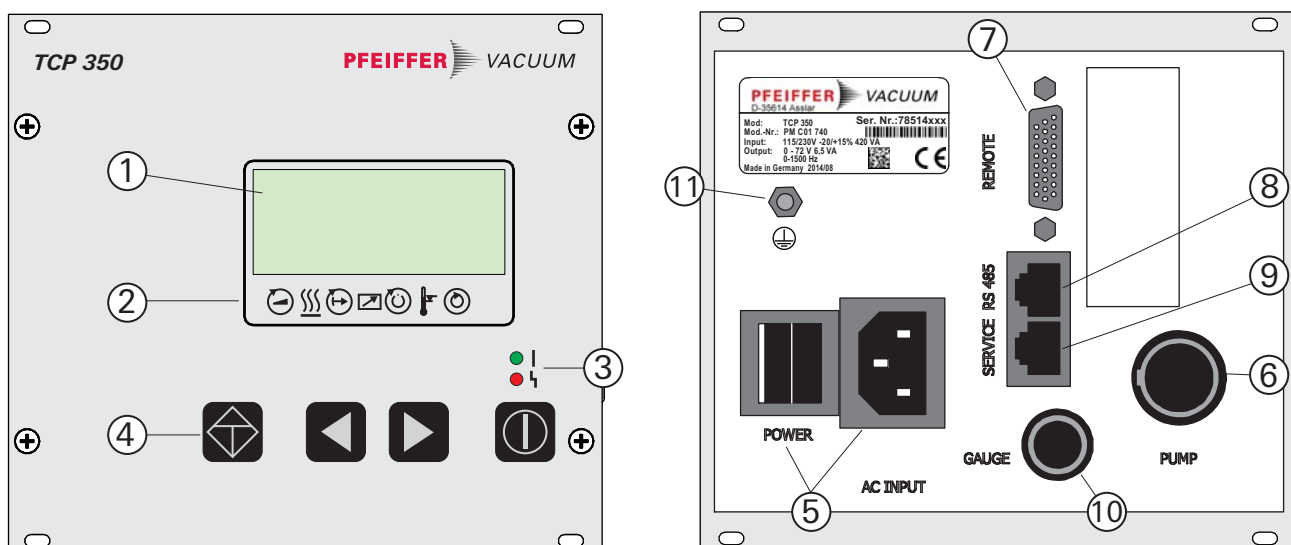

Fig. 2: TCP 350, Overview of controls and connections

- | | | |
|------------------------------|------------------------------------|------------------------|
| 1 LC display, illuminated | 5 Mains connection and main switch | 9 "SERVICE" connection |
| 2 Status icons | 6 "PUMP" connection | 10 "GAUGE" connection |
| 3 LEDs "Operation indicator" | 7 "REMOTE" connection | 11 Earth connection PE |
| 4 Controls | 8 "RS485" connection | |



3.3 Range of application

3.3.1 Cooling

Pfeiffer Vacuum electronic drive units TCP 350 must be installed and operated in the following ambient conditions.

| | |
|-----------------------|--|
| Installation location | weather protected (indoors) |
| Protection category | IP 20 |
| Protection class | I |
| Temperature | +5 °C to +40 °C |
| Relative humidity | max. 80 %, at T ≤ 31 °C, max. 50% at T ≤ 40 °C |
| Atmospheric pressure: | 750 hPa - 1060 hPa |
| Installation altitude | 2000 m max. |
| Degree of pollution | 2 |
| Overvoltage category | II |







Remarks to ambient conditions

The specified permissible ambient temperatures apply to operation of the turbopump at maximum permissible fore-vacuum pressure or at maximum gas throughput depending on the cooling method. The turbopump is intrinsically safe by a redundant temperature monitoring.

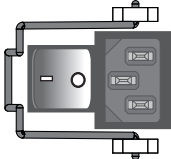
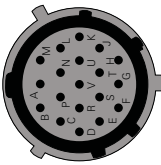
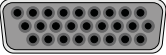
- By reducing the fore-vacuum pressure or gas throughput, the turbopump can be operated at higher ambient temperatures.
- If the maximum permissible operating temperature of the turbopump is exceeded, the electronic drive unit reduces drive power first and switches off then, if necessary.

3.4 Connection panel

| | |
|---|---|
|  | POWER/AC input C14 device connector for connecting a power cable with a C13 socket type from the Pfeiffer Vacuum accessories program. |
|  | PUMP Round plug connection, socket, 19-pin with three-point bayonet coupling for connecting a Pfeiffer Vacuum turbopump with connection cables of various lengths (max. 110 m in the standard version). |
|  | REMOTE High Density D-Sub connector, 26-pin for connecting and configuring a remote control. |
|  | RS485 RJ45 plug contact, 8-pin for connecting Pfeiffer Vacuum control devices (e.g., HPU) or a PC. |
|  | SERVICE RJ45 plug contact, 8-pin. This interface is used exclusively for Pfeiffer Vacuum Service purposes. |
|  | GAUGE Round plug connection, socket, 6-pin for pressure measuring for connecting an analog Pfeiffer Vacuum transmitter from the Active Line series. |



4 Wiring diagrams

4.1 TCP 350 with connecting cable and M12 accessories connector

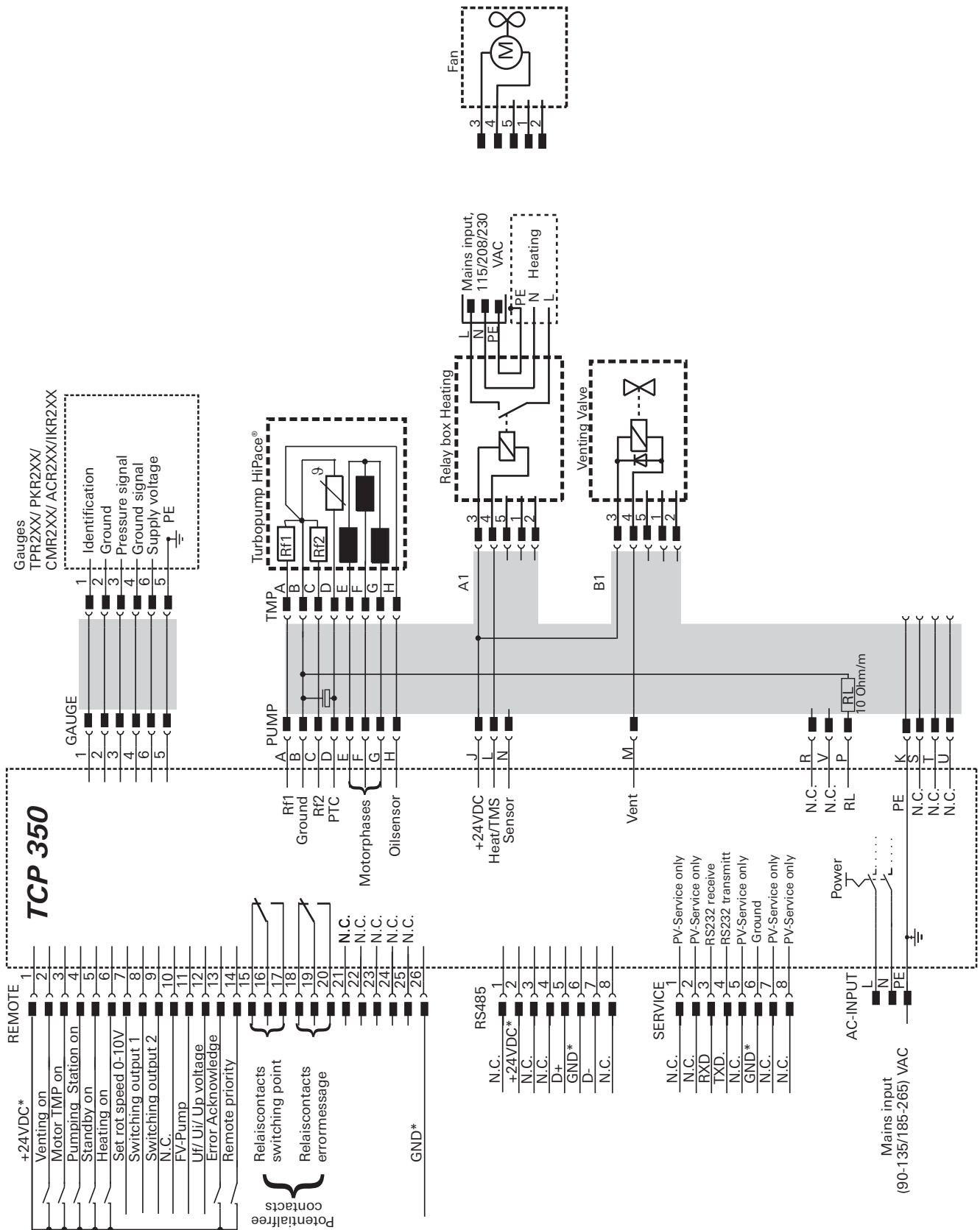

4.2 TCP 350 with connecting cable and M8 accessories connector

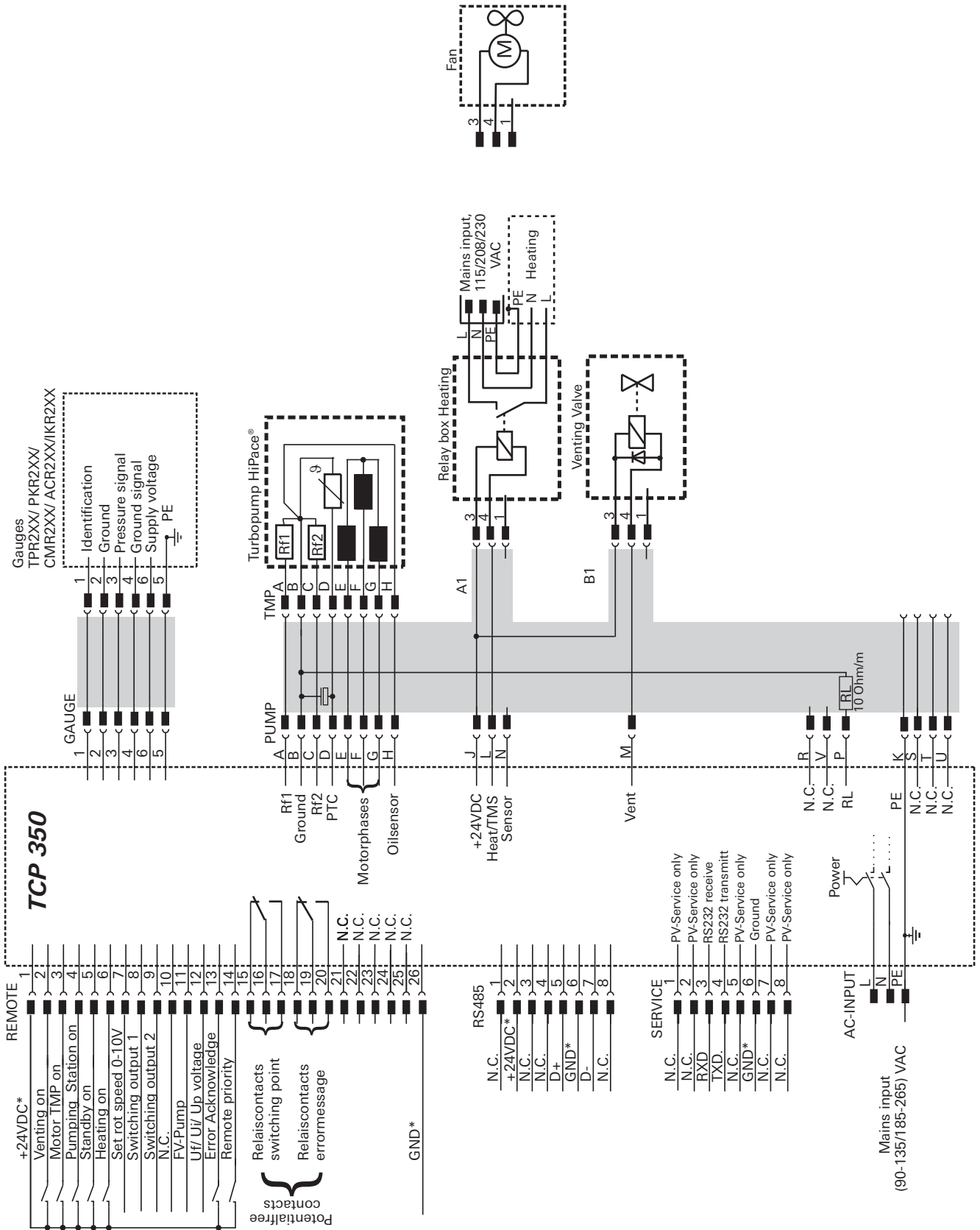

4.3 TCP 350 with connecting cable and RJ45 accessories connector

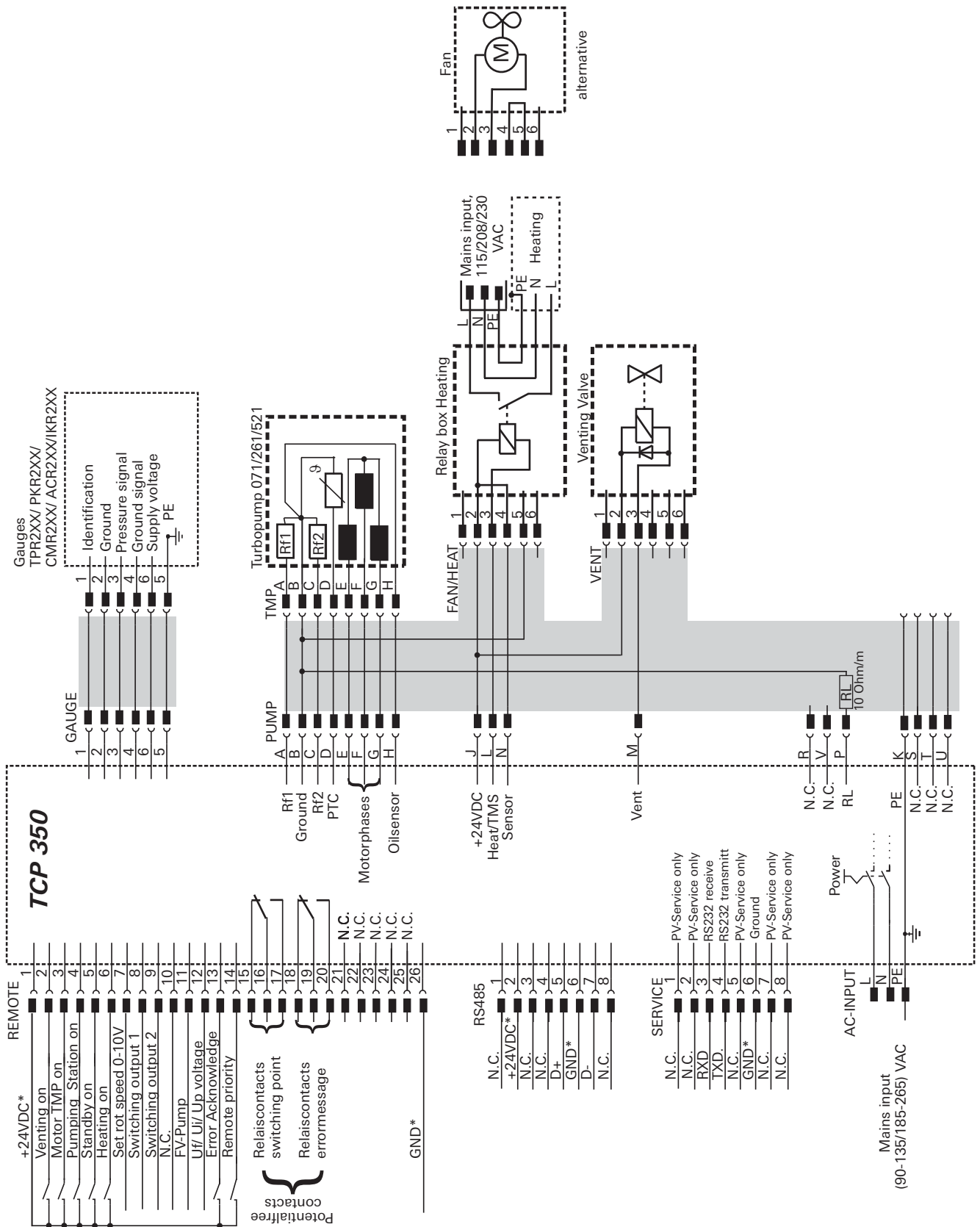

5 Installation

5.1 Assembly



NOTICE

Ensure free convection

Incorrect installation can cause damage by over-heating or create a fire hazard.

- Maintain a minimum distance of 50 mm from cooling vents to adjacent components or boundaries.
- Install the device upright.

5.1.1 Rack installation

The unit is fitted in a casing that is suitable for installation in 19"/3HE rack modules.

- Insert the unit in the guiderails of a 19"/3HE rack and screw on the front panel securely with four fixing screws provided as part of the scope of supply.
- Ensure sufficient air circulation if installed in enclosed housings.
- Do not hinder device internal air flow and removal.
- Ensure permissible ambient conditions in the rack cabinet (see p. 10, chap. 3.3).

5.2 Connections

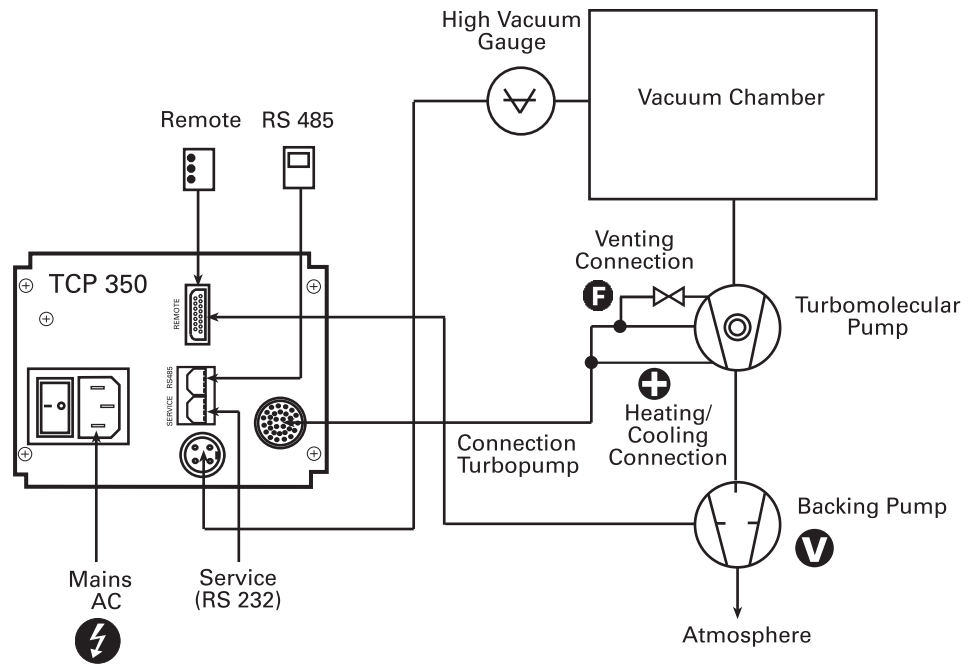
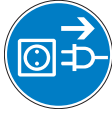

Fig. 3: General overview of the connections on the TCP 350



5.3 Connection "external pump"

The external connection of a Pfeiffer Vacuum turbopump to the electronic drive unit TCP 350 is possible, using shielded connection cables of different lengths from the Pfeiffer Vacuum accessories programme.



WARNING

Danger of electric shock

The system is only free of voltages if the mains plug is disconnected.

- Switch off the main switch and disconnect the mains plug before all work.
- Secure against unintentional restarting.
- Ensure the complete stop of the pump ($f < 1$).

CAUTION

Risk of tripping!

Risk of tripping when working in the installation area.

- Place supply lines in such a way that no tripping hazards occur.

The cable for control and operation of the turbopump is uniquely designated by plugs and sockets.

- Round connector, 18-pin for connecting to the TCP 350
- Socket, 8-pin with two control cables for accessories and earth cable for connecting to the turbopump



Connection to existing cable configurations

For special or existing configurations Pfeiffer Vacuum recommends the use of an adapt-cable between the TCP 350 and an existing connection cable to the turbopump.

- See the accessories recommendations for the turbopump in question.

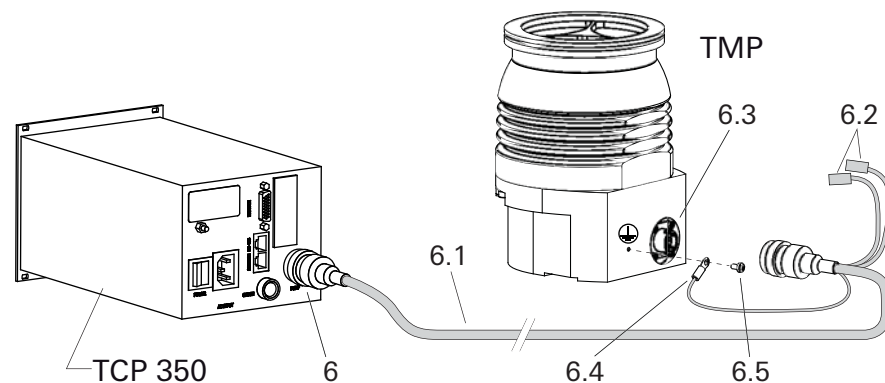

Fig. 4: Connecting the turbopump to the electronic drive unit TCP 350

- | | | | |
|-----|-----------------------------|-----|-------------------|
| 6 | Connection "pump" to TCP | 6.3 | "Pump" connection |
| 6.1 | TCP connection cable - pump | 6.4 | PE earth cable |
| 6.2 | Accessories connectors | 6.5 | Fasteners |

- Install the connection cable between the electronic drive unit and the turbopump.
- Lock plug connections and secure the bayonet fittings.
- Connect earth cable 6.4 from the connection cable directly with the earth terminal on the turbopump with the enclosed fastening material 6.5.



5.4 Earthing

Pfeiffer Vacuum recommends to connect an appropriate earthing wire to derive applicative interferences.

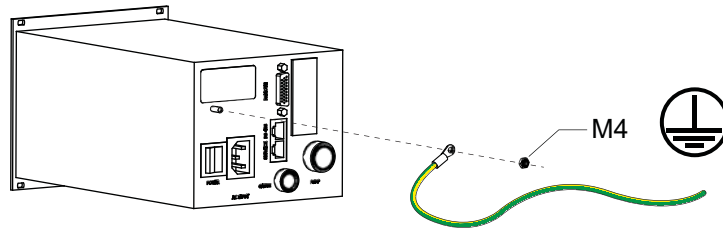

Fig. 5: Installing the earthing connection

5.5 Accessory connection

There are two connections (M8, M12 or RJ45) on the TCP 350 - turbopump connecting cable for the following accessories:

- **A1** or **FAN/HEAT**: Air cooling or heating
 - $I_{max} \leq 200$ mA
- **B1** or **VENT**: vent valve only
 - $I_{max} \leq 200$ mA

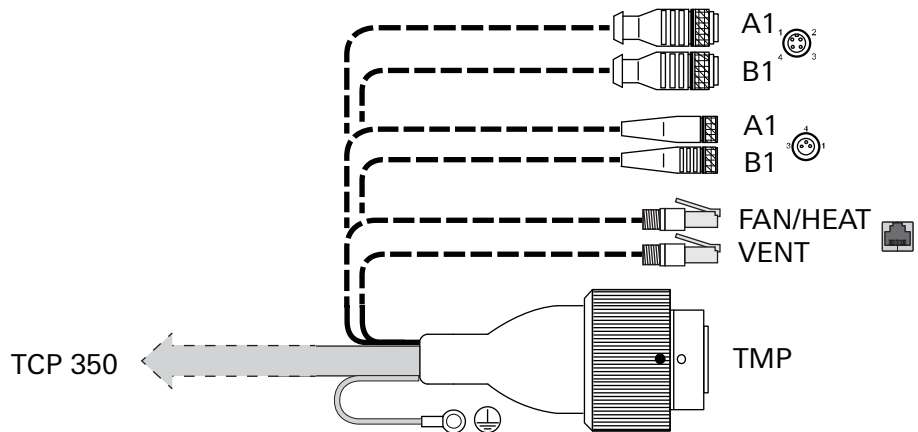

Fig. 6: Connection cable TCP 350 - turbopump with variants of the accessory connection

- For connection and operation of the accessory please refer to the relevant operating instructions of the turbopump.
- Connect the accessory control cable to the appropriate connection on the connecting cable.
- Configure settings and controls via the interfaces of the electronic drive unit (only applies to A1, or FAN/HEAT).

Special features:

The connected accessories are activated after commissioning the electronic drive unit.

- Use adapters from the Pfeiffer Vacuum accessory range for the turbopump to ensure compatibility with existing configurations.
- Do not connect a relaybox for the backing pump to the connecting cable; instead use an adapter cable connected to the TCP 350 electronic drive unit "Remote" output.
- Use a sealing gas throttle instead of a sealing gas valve.



5.6 Connection "RS-485"

5.6.1 Connections

A Pfeiffer Vacuum display and control panel (DCU or HPU) or an external PC can be connected to the electronic drive unit via the connection designated "RS-485". The interface is electrically isolated from the maximum supply voltage of the electronic drive unit. The electrical couplings are optically decoupled internally.

| Designation | Value |
|------------------|------------------|
| Serial interface | RS-485 |
| Baud rate | 9600 bauds |
| Data word length | 8 bits |
| Parity | none (no parity) |
| Start bits | 1 |
| Stop bits | 1 |



1

| Pin | Assignment |
|-----|---------------------------------|
| 1 | not connected |
| 2 | +24 V output ≤ 150 mA max. load |
| 3 | not connected |
| 4 | not connected |
| 5 | RS485 D+ |
| 6 | GND |
| 7 | RS485 D- |
| 8 | not connected |

→ The connection of respectively one external operating unit is possible on the interface RS-485.

→ A USB interface (PC) can be connected via the USB/RS-485-converter.

5.6.2 Cross-linking via the connection RS-485

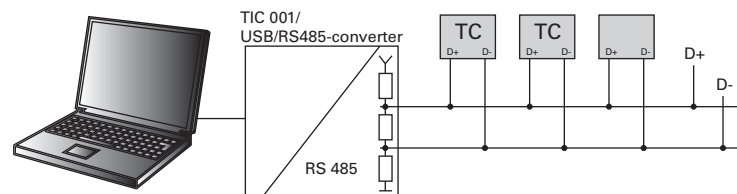

CAUTION

Danger of electric shock

The insulation measures of the bus system are designed only for use with safety extra-low voltage.

→ Connect only suitable devices to the bus system.

→ Establish the connections according to the specification of the interface RS-485.

→ Connect all units with RS-485 D+ and RS-485 D- to the bus.

- The group address of the electronic drive unit is 988.
- All units connected to the bus must have differing RS-485 device addresses [P:797].



Connecting to an external bus system

It is only possible to connect to an external bus system (e.g., Profibus DP, DeviceNet) on devices with a connection gateway TIC 253 or TIC 263. The simultaneous use of the RS485 interface is not possible in this case.

- The field bus option cannot be retrofitted on the standard device.



5.7 "SERVICE" connection

5.7.1 Connections

The connection labelled "SERVICE" on the electronic drive unit is used exclusively for service and configuration purposes. The RS-232 interface is safely electrically isolated from the maximum supply voltage that can occur in the electronic drive unit. The electrical connections are optically decoupled internally.

| Designation | Value |
|------------------|------------------|
| Serial interface | RS-232 |
| Baud rate | 9600 bauds |
| Data word length | 8 bits |
| Parity | none (no parity) |
| Start bits | 1 |
| Stop bits | 1..2 |



| Pin | Assignment |
|-----|--------------|
| 1 | Service only |
| 2 | Service only |
| 3 | RS 232 RxD |
| 4 | RS 232 TxD |
| 5 | Service only |
| 6 | GND |
| 7 | Service only |
| 8 | Service only |

5.8 Connection "REMOTE"

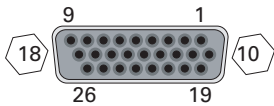

Remote control is possible via the 26-pin D-sub connector labelled "REMOTE" on the electronic drive unit. The accessible individual functions are mapped to "PLC levels".

| Input signals | Output signals |
|--|--|
| <ul style="list-style-type: none"> – PLC High level: +13 to +33 V DC – PLC Low level: -33 to +7 V DC – Ri: 7 kΩ | <ul style="list-style-type: none"> – High level: +20 to +28 V DC – Low level: 0 to +3 V DC |

Table 1: Logic levels of digital inputs and outputs on REMOTE

→ Shielded connectors and cables must be used.

The following information display the factory setting. Configuration is possible using the Pfeiffer Vacuum parameter set.

5.8.1 Pin assignment

| Pin | Function | Description, factory setting |
|-----|---------------------------------|---|
| 1 | +24 V DC* output (V+) | Reference voltage for all digital inputs and outputs: |
| 2 | DI1 | Release vents; Low: off; High: on |
| 3 | DI motor pump | Drive motor; Low: off; High: on |
| 4 | DI Pumping station | Low: off; High: on |
| 5 | DI Standby | Standby speed; Low: off; High: on |
| 6 | DI2 | Heater; Low: off; High: on |
| 7 | AI+ rotation speed setting mode | Default in rotation speed setting mode; 2-10 V DC is equivalent to 20-100% of the nominal speed |
| 8 | DO1 | Speed-control switching point reached; Low: no; High: yes ($I_{max} = 50 \text{ mA}$) |
| 9 | DO2 | Low: Fault; High: no faults ($I_{max} = 50 \text{ mA}$) |
| 10 | | not assigned |
| 11 | DO control backing pump | Backing pump ON; Low: no; High: yes ($I_{max} = 50 \text{ mA}$) |
| 12 | AO voltage Vf, Vp, Vi | 0-10 V DC is equivalent to 0-100%; $R_L > 10 \text{ k}\Omega$ |
| 13 | DI Fault acknowledgement | Fault acknowledgement High: Pulse (min. 500 ms) |



| Pin | Function | Description, factory setting |
|-----|--------------------|---|
| 14 | DI Remote priority | Control via interface "REMOTE"; low: off; high: set and takes priority over keypad or RS485 |
| 15 | Relay 1 | Connection with pin 16, relay 1 active = switching point reached |
| 16 | | Relay contact 1 ($V_{\max} = 50 \text{ V DC}$; $I_{\max} = 1 \text{ A}$) |
| 17 | | Connection with pin 16, relay 1 inactive = switching point not reached |
| 18 | Relay 2 | Connection with pin 19, relay 2 active = no fault |
| 19 | | Relay contact 2 ($V_{\max} = 50 \text{ V DC}$; $I_{\max} = 1 \text{ A}$) |
| 20 | | Connection with pin 19, relay 2 inactive = fault |
| 21 | | not assigned |
| 22 | | not assigned |
| 23 | | not assigned |
| 24 | | not assigned |
| 25 | | not assigned |
| 26 | Earth (GND*) | Reference earth for all digital inputs and outputs: |

5.8.2 +24 V DC* Output / Pin 1

Inputs 2 - 6 and the connections to Pins 13, 14 are activated by connecting them with +24 V DC to Pin 1 (active high). They can also be activated via an external PLC.

5.8.3 Inputs

The digital inputs at connection "REMOTE" are used to connect various functions of the electronic drive unit.

DI1 (Enable venting) / Pin 2

V+ : Venting is enabled (venting according to venting mode)

open: Venting locked (no venting is performed)

DI Motor pump / Pin 3

After Pin 4 (pumping station) is activated and the electronic drive unit successfully completes the self-test, the turbopump is placed into operation. During operation, the turbopump can be switched off and on again, while the pumping station remains switched on. The turbopump is not vented thereby.

V+ : Turbopump motor on

open: Turbopump motor off

DI Pumping station/Pin 4

Connected pumping station components are actuated (e.g., backing pump, air cooling) and if pin 3 (motor) is activated at the same time, the turbopump is switched on.

V+ : Pumping station on

open: Pumping station off

DI Standby / Pin 5

In standby mode, the turbopump operates at a specified rotor speed < nominal rotation speed. Factory setting and recommended operation are 66.7 % of the nominal rotation speed.

V+ : Standby activated

open: Standby off, operation at nominal rotation speed

DI2 (Heating) / Pin 6

V+ : Heating on

open: Heating off



DI Error acknowledgement / Pin 13

V+ : Reset ongoing error messages when cause has been eliminated with a pulse of min. 500 ms duration.

open: Inactive

DI Remote/Pin 14

Active High: The "REMOTE" connection takes priority over the operation via keypad or interface.

- Activated individual functions cannot be changed via the keypad or interface.
- Individual functions deactivated via "REMOTE" can be controlled using the keypad or interface.

Low: Remote priority inactive

AI Rotation speed setting mode / Pin 7 and Pin 26

The analog input defines the set rotation speed of the turbopump. An input signal of 2 - 10 V between AI+ (Pin 7) and GND (Pin 26) corresponds to a rotation speed within the range of 20 - 100% of the nominal rotation speed. If the input is open or signals fall below 2 V, the pump is accelerated up to nominal rotation speed.

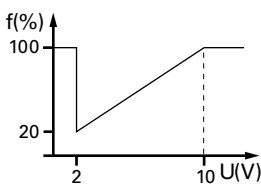

5.8.4 Outputs

The digital outputs on the "REMOTE" connection can handle a max. load of 50 mA per output. Some outputs are configurable with the Pfeiffer Vacuum parameter set via the RS-485 interface (description relates to factory settings).

DO1 (Rotation speed switchpoint attained) / Pin 8

Active high after the rotation speed switchpoint is attained. Rotation speed switchpoint 1 is factory-set to 80% of the nominal rotation speed. It can, for example, be used for a "pump operational" message.

DO2 (No errors) / Pin 9

When the supply voltage has been established, digital output DO2 permanently outputs 24 V DC which means "no errors". Active low in case of error (collective error message).

AO analog output 0-10 V DC / Pin 12

- 0 - 10 V DC is equivalent to 0 - 100 % x f_{Nominal}

A voltage V_f can be tapped via the analog output; it is proportional to the turbopump speed (load $R \geq 10 \text{ k}\Omega$). Alternatively, either the current (V_i) or output (V_p) can be assigned via keypad input or interface.

5.8.5 Relay contacts

Relay 1 / Pin 15, 16 and 17

The contact between pin 16 and pin 15 is closed if the speed switching point is reached or exceeded - relay 1 is active. The contact between pin 16 and pin 17 is closed if the speed switching point is not reached or undershot - relay 1 is inactive. Relay control follows digital output pin 8.



Relay 2 / Pin 18, 19 and 20

The contact between pin 19 and pin 18 is closed in case of trouble-free operation - relay 2 is active. The contact between pin 19 and pin 20 is closed if an error has occurred - relay 2 is inactive. Relay control follows digital output pin 9.

5.9 Connecting a measuring device

The connector socket labelled "*Gauge*" can be used to operate a Pfeiffer Vacuum pressure measuring device from the ActiveLine series.

| Gauges | P_{\min} (hPa) | P_{\max} (hPa) |
|---------|-----------------------|------------------|
| TPR 2xx | $5 \cdot 10^{-4}$ hPa | 1000 hPa |
| IKR 2xx | $2 \cdot 10^{-9}$ hPa | 0,01 hPa |
| PKR 2xx | $5 \cdot 10^{-9}$ hPa | 1000 hPa |
| CMR x61 | $1 \cdot 10^{-1}$ hPa | 1100 hPa |
| CMR x62 | $1 \cdot 10^{-2}$ hPa | 110 hPa |
| CMR x63 | $1 \cdot 10^{-3}$ hPa | 11 hPa |

Table 2: Usable types of gauges for TCP 350

5.10 Connecting to the mains power supply



WARNING

Danger of unsafe electrical installation

Safe operation after installation is the responsibility of the operator.

- Do not independently modify or change the pump and electrical equipment.
- Make sure that the system is integrated in an emergency off safety circuit.
- Consult Pfeiffer Vacuum for special requirements.



WARNING

Danger of electric shock

In case of defect, the parts connected to the mains supply are under voltage.

- Always keep the mains connection freely accessible so that you can disconnect it at any time.
- Order the mains cable separately (see "accessories").
- Switch off the main switch 5 on the electronic drive unit to position "0".
- Plug mains cable into the mains connection "AC in".
- Lock the mains cable with the mounting bracket.
- Connect the mains cable to the mains.
- Always ensure a safe connection to the protective earthing conductor (PE, protection class I).



6 The Pfeiffer Vacuum parameter set

6.1 General

All function-relevant variables of a turbopump are anchored in the electronic drive unit as parameters. Each parameter has a three-digit number and a designation. Parameters can be used via Pfeiffer Vacuum display and control units or via RS-485 with the Pfeiffer Vacuum protocol.



Additional parameters in the control unit

For the control of connected external components (e.g. vacuum measurement devices) there are additional parameters fixed in the respective Pfeiffer Vacuum display and control unit.

→ Please consider the respective operating instructions.

6.1.1 Conventions

Parameters are displayed in square brackets as a three-digit number in bold font. The designation may also be stated if necessary.

Example: **[P:312]** Software version

6.2 Parameter overview

6.2.1 Annotation

| | |
|----------------------|---|
| # | Three figure number of the parameter |
| Display | Display of the parameter name in the LCD * = Representation as a symbol, if necessary |
| Designation | Short description of the parameter |
| Functions | Functional description of the parameter |
| Data type | Type of formatting of the parameter for the use within the Pfeiffer Vacuum protocol |
| Access method | R: read access; W: write access |
| Unit | Physical unit of the described characteristic |
| min / max | Permissible limits for value input |
| default | Factory settings (partially specific of the pump type) |
| | Parameter can be stored non volatile in the electronic drive unit and may be re-used after resetting of the mains supply. |



Parameter set and Pfeiffer Vacuum display and control unit

Pfeiffer Vacuum display and control units show the basic parameter set by default.

→ Parameter **[P:794]** = 1 (Display of all available parameters).

6.2.2 Control commands

| # | Display | Designation | Functions | Data type | Access | Unit | min | max | default | |
|------------------|------------|-----------------------|----------------------------|-----------|--------|------|-----|-----|---------|---|
| 001 | Heating | Heating | 0 = off 1 = on | 0 | RW | | 0 | 1 | 0 | x |
| 002 | Standby | Standby | 0 = off 1 = on | 0 | RW | | 0 | 1 | 0 | x |
| 004 | RUTime ctr | Run-up time control | 0 = off 1 = on | 0 | RW | | 0 | 1 | 1 | x |
| 008 | Keys lockd | Keys locked | 0 = off 1 = keys locked | 0 | RW | | 0 | 1 | 0 | |
| 009 ¹ | | Fault acknowledgement | 1 = Fault acknowledgement | 0 | W | | 1 | 1 | | |
| 010 | Pump stat. | Pumping station | 0 = off 1 = on | 0 | RW | | 0 | 1 | 0 | x |









| # | Display | Designation | Functions | Data type | Access | Unit | min | max | default | |
|-----|-------------|---|--|-----------|--------|------|-----|-----|---------|---|
| 012 | Vent enab | Enable venting | 0 = no 1 = yes | 0 | RW | | 0 | 1 | 0 | x |
| 019 | Conf. Out 2 | Configuration output DO2 | 0 = mains "OFF" or fault 1 = mains "OFF" or fault or warning 2 = mains "OFF" or fault or turbopump drive "OFF" | 7 | RW | | 0 | 2 | 1 | x |
| 023 | Motor TMP | Motor pump | 0 = off 1 = on | 0 | RW | | 0 | 1 | 0 | x |
| 025 | OpMode BKP | Backing pump operating mode | 0 = continuous operation 1 = intermittent operation | 7 | RW | | 0 | 1 | 0 | x |
| 026 | OpMode TMP | Rotation speed setting mode | 0 = off, ultimate speed operation 1 = on, rotation speed setting mode | 7 | RW | | 0 | 1 | 0 | x |
| 027 | gas mode | Gas mode | 0 = heavy gases 1 = light gases | 7 | RW | | 0 | 1 | 0 | x |
| 028 | Opmode Rem | Operating mode interfaces | 0 = no priorities 1 = Remote priority, for pin 14 active high | 7 | RW | | 0 | 1 | 0 | x |
| 030 | Vent mode | Venting mode | 0 = delayed venting 1 = do not vent 2 = vent directly | 7 | RW | | 0 | 2 | 0 | x |
| 035 | Conf IO | Accessory output configuration | 0 = Heating 2 = Fan | 7 | RW | | 0 | 2 | 0 | x |
| 055 | Conf AO1 | Configuration output AO1 | 0 = actual speed 1 = output: 2 = current | 7 | RW | | 0 | 2 | 0 | x |
| 095 | RstCstVals | Reset to factory settings (relates to actuating instructions and setpoints) | no yes | 0 | W | | - | - | no | x |

1.*

* = No text display of the parameter, instead symbol or key operated

6.2.3 Status requests

| # | Display | Designation | Functions | Data type | Access | Unit | min | max | default | |
|------|---|--|--------------------------------|-----------|--------|------|-------|--------|---------|---|
| 300* |  | Remote priority | 0 = no 1 = yes | 0 | R | | 0 | 1 | | |
| 301 | Oil defic | Operating fluid deficiency | no yes | 0 | R | | 0 | 1 | | |
| 302* |  | Rotation speed switchpoint attained | 0 = no 1 = yes | 0 | R | | 0 | 1 | | |
| 303 | Error code | Error code | no Err Err XXX Wrn XXX | 4 | R | | | | | |
| 304* |  | Excess temperature electronic drive unit | | 0 | R | | | | | |
| 305* |  | Excess temperature pump | | 0 | R | | | | | |
| 306* |  | Set rotation speed attained | | 0 | R | | | | | |
| 307* |  | Pump accelerating | | 0 | R | | | | | |
| 308 | Set rotspd | Set rotation speed (Hz) | | 1 | R | Hz | 0 | 2000 | | |
| 309 | Act rotspd | Actual rotation speed (Hz) | | 1 | R | Hz | 0 | 2000 | | |
| 310 | TMP I-mot | Drive motor current | | 2 | R | A | 00:00 | 15:00 | | |
| 311 | TMP Op hrs | Pump operating hours | | 1 | R | h | 0 | 65535 | | x |
| 312 | PCS Softw. | Electronic drive unit software version | | 4 | R | | | 999999 | | |
| 313 | TMP DClint | Drive motor voltage | | 2 | R | R | 0 | 127.50 | | |
| 314 | Drv Op hrs | Electronic drive unit operating hours | | 1 | R | h | 0 | 65535 | | x |
| 315 | TMP finspd | Nominal rotation speed (Hz) | | 1 | R | Hz | 0 | 2000 | | |
| 316 | TMP Power | Drive motor output | | 1 | R | W | 0 | 500 | | |
| 319 | Cycl count | Pump cycles | | 1 | R | | 0 | 65535 | | x |
| 335 | HeatType | Accessory connector assignment | 0 = Heating 2 = Air cooling | 7 | R | | 0 | 255 | | |
| 340 | Pressure | Actual pressure value (ActiveLine) | | 7 | R | hPa | 1E-12 | 1.0E3 | | |
| 349 | Drv Name | Drive type electronic drive unit | | 4 | R | | | TCP350 | | |



| # | Display | Designation | Functions | Data type | Access | Unit | min | max | default | |
|-----|-------------|--|--------------------|-----------|--------|------|-----|--------|---------|---|
| 352 | Drv Softw. | Software version motor control | | 4 | R | | | 999999 | | |
| 354 | HW version | Hardware version electronic drive unit | | 4 | R | | | | | |
| 360 | Past Err 1 | Error code history, item 1 | last error message | 4 | R | | | | | x |
| 361 | Past Err 2 | Error code history, item 2 | | 4 | R | | | | | x |
| 362 | Past Err 3 | Error code history, item 3 | | 4 | R | | | | | x |
| 363 | Past Err 4 | Error code history, item 4 | | 4 | R | | | | | x |
| 364 | Past Err 5 | Error code history, item 5 | | 4 | R | | | | | x |
| 365 | Past Err 6 | Error code history, item 6 | | 4 | R | | | | | x |
| 366 | Past Err 7 | Error code history, item 7 | | 4 | R | | | | | x |
| 367 | Past Err 8 | Error code history, item 8 | | 4 | R | | | | | x |
| 368 | Past Err 9 | Error code history, item 9 | | 4 | R | | | | | x |
| 369 | Past Err 10 | Error code history, item 10 | | 4 | R | | | | | x |

* = No text display of the parameter, instead symbol or key operated

6.2.4 Set value settings

| # | Display | Designation | Functions | Data type | Access | Unit | min | max | default | |
|-----|------------|--|--|-----------|--------|------|------|-------|---------|---|
| 700 | TMP RUTime | Run-up time desired value | | 1 | RW | min | 1 | 120 | 8 | x |
| 701 | Switch pnt | Set rotation speed | | 1 | RW | % | 50 | 97 | 80 | x |
| 707 | TMProt set | Setpoint in rotation speed setting mode | | 2 | RW | % | 20.0 | 100.0 | 50.0 | x |
| 710 | BkP Poff | Backing pump switch-off threshold for intermittent operation | | 1 | RW | W | 0 | 1000 | 0 | x |
| 711 | BkP Pon | Backing pump switch-on threshold for intermittent operation | | 1 | RW | W | 0 | 1000 | 0 | x |
| 717 | Stbyrotset | Rotation speed setpoint in standby operation | | 2 | RW | % | 20 | 100 | 66.7 | x |
| 720 | Vent frequ | Venting frequency in % of ultimate speed | | 7 | RW | % | 40 | 98 | 50 | x |
| 721 | Vent time | Venting time | | 1 | RW | d | 6 | 10800 | 3600 | x |
| 738 | Gauge type | Type of pressure gauge | noGaug TPR2xx IKR2xx PKR2xx CMRx61 CMRx62 CMRx63 | 1 | RW | | 0 | 6 | 0 | x |
| 777 | PumpRotMax | Confirmation of nominal rotation speed (Hz) | | 1 | RW | Hz | 0 | 2000 | 777 | x |
| 794 | Param. set | Parameter set | 0 = Basic parameter set 1 = Extended parameter set | 7 | RW | | 0 | 1 | 0 | |
| 795 | ServiceLin | Insert service line | | 7 | RW | | | | 309 | |
| 797 | Address | Device address | | 1 | RW | | 1 | 255 | 1 | x |



7 Operation

7.1 Switching on

→ Switch on the main switch 5 to position "1".

7.1.1 Self-test

The TCP carries out a self-test and a check of the connected units after switch-on. The duration of the self-test is approx. 5 s and is visualized in the display with a progress bar.

→ Reset malfunction messages using key , if necessary.

On commissioning the electronic drive unit, or after changing the connected turbopump, the error message **E777** appears in the display.

→ Reset error E777 by setting the valid nominal rotation speed of the respective pump (see p. 29, chap. 8.2).

7.2 LC-Display

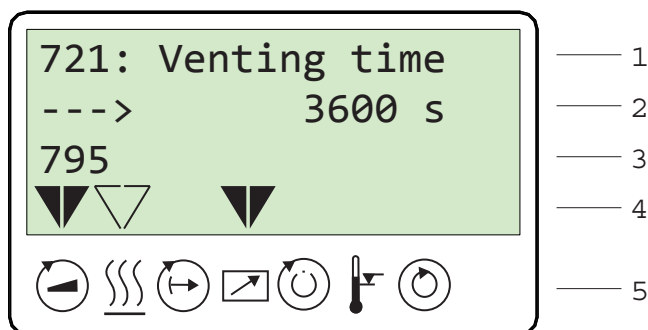

The four line LCD visualizes the functions of the TCP.

Functions are assigned as follows:

- **Line 1:** Number and name of the selected parameter (e.g. 721: Vent time).
- **Line 2:** relevant value for the selected parameter. The arrow \longrightarrow indicates Edit mode.
- **Line 3** with two functions:
 - Function 1: Current messages concerning operation and control will be displayed.
 - Function 2: presentation of a required second parameter in the format [Parameter number: value]. The function for this line can be set via parameter **[P:795] Servicelin** in Line 1. All parameters can be accessed with "Servicelin". Error messages will be displayed independently of the selected function.
- **Line 4:** presentation of the current equipment status by arrows that point to the associated symbols.
- **Line 5:** Symbols (see below)



7.3 Symbol description

| Symbol | Description | Arrow | Explanation |
|--------|--|-------|--|
| | Pump accelerates = [P:307] | - | NO |
| | | ▼ | YES |
| | Preselection heating = [P:001] | - | No preselection |
| | | ▽ | Preselection heating, switchpoint not attained |
| | | ▼ | Heating On, switchpoint attained |
| | Standby = [P:002] | - | OFF |
| | | ▼ | ON |
| | Equipment remote controlled = [P:300] | - | NO |
| | | ▼ | YES |
| | Switchpoint reached = [P:302] | - | NO |
| | | ▼ | YES |
| | Excess temperature | - | No excess temperatures |
| | | ▽ | Excess temperature turbopump = [P:305] |
| | | ▽ | Excess temperature turbo-electronics = [P:304] |
| | | ▼ | Excess temperature turbopump and turbo-electronics |
| | Ultimate speed reached = [P:306] | - | NO |
| | | ▼ | YES |

7.4 Key functions

4 short-travel keys (softkeys) constitute the operator interface for the TCP.



| Key | Application/Example | Explanation |
|------------------|---------------------------------------|--|
| | | Reset (error acknowledgement) acknowledges errors (red LED illuminates) |
| | [309]: ActualSpd [308]: SetRotSpd | Scroll back through parameters Scrolls back one parameter |
| | [310]: DrvCurrent [311]: OpHrsPump | Scroll forwards through parameters Scrolls forwards one parameter |
| Simultaneous | [001]: Heating →▶ off | Change value (Edit mode) Access to displayed value, if possible (Arrow→▶ is displayed) |
| | [001]: Heating on | Confirm value (Parameter selection mode) Accept changed value ("change confirmed" is displayed) |
| | [010]: PumpgStatn on / off | Pumping station ON/OFF switches pumping station on or off. corresponds to parameter [010]: "PumpgStatn" |



7.5 Operation

All function-relevant variables of a turbopump are anchored in the electronic drive unit as parameters. Each parameter has a three-digit number and a designation. Parameters can be used via Pfeiffer Vacuum display and control units or via RS-485 with the Pfeiffer Vacuum protocol.

The value of a parameter is always readable. Editable parameters are adjustment commands and target values (See the operating instructions for the respective electronic drive unit for this purpose).

7.5.1 Selecting the parameters

- Preselect parameter number using the ◀ (backwards) or ▶ (forwards) keys.
 - Fast scrolling by pressing and keeping the relevant key depressed.
- The selected parameter appears in line 1, the corresponding value in line 2.

7.5.2 Set parameters

- Select a parameter.
- Simultaneously press keys ◀ and ▶ .
 - The edit mode for the selected parameter is active.
 - At the beginning of the second line an arrow (—▶) appears.
- Using keys ◀ , ▶ to decrease or increase the value, respective to change options.
- Simultaneously press keys ◀ and ▶ .
 - If line 3 = empty (see P:795), the following will be displayed: "change confirmed"
 - The parameter is set.
 - Edit mode for the parameter is ended. The arrow (—▶) disappears.

Edit mode(—▶) will disappear again automatically under the following conditions and without accepting the value to be changed:

- Input disruption or no key operation for more than 10s.
- If an error occurs.
- Key "Pumping station ON/OFF" has been pressed.
- If line 3 = empty , "data not changed" will be displayed.



Start pump by pressing "Pumping station ON/OFF" key

The "Pumping station" key only controls the parameter [P:010]. All components connected via the electronic drive unit will be activated or deactivated according to their configuration.

- Ensure that the parameter [P:023] is also switched on for powering-up the turbopump.



7.6 Configuring the connections

7.6.1 DO2 and relay on "REMOTE"

→ Configuration via parameter **[P:019]** .

- In the description "active" means (trouble-free):
 - For DO2: V+ active high
 - For relay 2: Active contact change
- Pending errors mean:
 - For DO2: low
 - For relay 2: inactive

| Option | Description |
|---|--------------------------------|
| 0 = mains "OFF" and/or fault | DO2 "low" and relay 2 inactive |
| 1 = mains "OFF" and/or fault and/or warning | |
| 2 = mains "OFF" and/or fault and/or drive OFF | |

7.6.2 Analog output on "REMOTE"

→ Configuration via parameter **[P:055]**.

| Option | Description |
|--------------------|---|
| 0 = Rotation speed | Speed signal; 0 - 10 V DC = 0 - 100 % x $f_{Nominal}$ |
| 1 = output: | Output signal; 0 - 10 V DC = 0 - 100 % x P_{max} |
| 2 = current | Current signal; 0 - 10 V DC = 0 - 100 % x I_{max} |

7.6.3 Accessory connection

→ Configuration via parameter **[P:035]** .

| Option | Description |
|-----------------|---|
| 0 = Heating | Control via heating and rotation speed switchpoint reached parameters |
| 1 = TMS Heater* | Control via TMS switchbox |
| 2 = fan | Control via pumping station parameters |

* Only when using pumps with a temperature management system (TMS)



8 Operation with the Pfeiffer Vacuum parameter set

8.1 General

8.1.1 Factory settings

The electronic drive unit is pre-programmed in the factory. This guarantees proper, reliable turbopump operation without the need for additional configuration.

- Restore factory settings via parameter **[P:095]** if necessary.
 - **Attention!** All customized settings will be lost.

8.1.2 Checking the adjustments

- Before operating with parameters, check set values and control commands for their suitability for the pumping process.
- Remove the remote plug from electronic drive unit if required.

8.1.3 Keypad lock

The control keys on the front of the electronic drive unit can be locked against unauthorised use.

- Locking of the keypad via parameter **[P:008]**.
 - All of the keypad input functions are disabled.
 - It is still possible to scroll through the parameter list.
- The keypad can only be unlocked by:
 - Interfaces RS485/RS232
 - De-energising through power OFF. The connected pump must run down completely to idle ($f = 0$).

8.2 Rotation speed set value

The typical nominal rotation speed of a turbopump is factory-set in the electronic drive unit. If the electronic drive unit is replaced or a different pump type is used, the reference set value of the nominal rotation speed must be confirmed. This procedure is part of a redundant safety system for avoiding excess rotation speeds.

- Adjust the parameter **[P:777]** according to the pump type.

Once the nominal rotation speed is attained, the pump will run idle unless additional gas loads are entered. Depending on process or application requirements, the nominal rotation speed can be reduced in rotation speed setting mode or standby mode.

| Pump type | Nominal rotation speed, settings for [P:777] in Hz |
|------------------------|---|
| CompactTurbo 071 P | 1500 |
| CompactTurbo 261/262 P | 1000 |
| CompactTurbo 261 P C | 833 |
| CompactTurbo 521 P | 833 |
| CompactTurbo 521 P C | 715 |
| HiPace 60 P | 1500 |
| HiPace 80 | 1500 |
| HiPace 300 | 1000 |
| HiPace 400 | 820 |
| HiPace 700 | 820 |
| HiPace 800 | 820 |



8.3 Remote control

There are basically three remote control options with different priorities. The advantage of the remote control feature is the ability to connect multiple electronic drive units via "REMOTE".

8.3.1 Standard operation

Standard operation generally means operation via TCP 350 keypad without explicit prioritisation of user interfaces. Beyond this, controls and functions are supported via the RS-485 interface. Similarly, the switching functions of the "REMOTE" connection are available if connected.

→ Parameter **[P:028]** = 0

- **Exception:** Connecting pin 14 on REMOTE with +24 V DC assigns priority to the functions on this connection and locks them for the other interfaces.

8.3.2 REMOTE Priority ON

Connection "REMOTE" on the electronic drive unit has priority over all the functions of the other interfaces.

→ Parameter **[P:028]** = 1

→ Pin 14 = active High

- **Exception:** Error acknowledgement is still possible via the corresponding key.

8.3.3 REMOTE Priority OFF

Connection "REMOTE" on the electronic drive unit does not have priority over the functions of the other interfaces.

→ Parameter **[P:028]** = 1

→ Pin 14 = active low

- **Exception:** Error acknowledgement is not possible via pin 13 until pin 14 "active high" again.

8.4 Gas type dependent operations



NOTICE

Danger of the pump being destroyed

Pumping of gases with a higher molecular mass in the wrong gas mode can lead to destruction of the pump.

→ Ensure the gas mode is correctly set.

→ Contact Pfeiffer Vacuum before using gases with a greater molecular mass (> 80).

Friction causes the rotor to heat up severely under gas load and high rotation speed. To avoid overheating, the electronic drive unit has implemented power-rotation speed-characteristics, whereby the pump can be operated at every rotation speed with the maximum allowable gas load without danger of damage. The maximum power consumption depends on the gas type. Three characteristics are available in order to completely exhaust the pump's capacity for each gas type.

- Gas mode "0" for gases with the molecular mass >39, e.g. argon.
- Gas mode "1" for gases with the molecular mass ≤ 39.
- Power characteristics according to the technical data of the turbopump.

→ Check and set-up the gas mode via **[P:027]**.



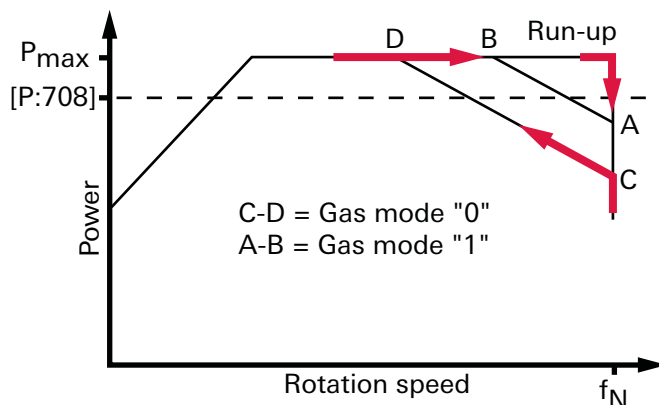

Fig. 7: Principle of power characteristics lines for gas type dependent operations, e.g. gas mode = 0

The turbopump runs up with maximum power consumption. When the nominal and/or set rotation speed is reached, the pump automatically switches over to the chosen power characteristic of the selected gas mode. Increasing gas load is initially compensated by a rise in power consumption in order to keep the rotation speed constant. Increasing gas friction, however, causes the turbopump to heat up more severely. When the gastype-dependent maximum power is exceeded, the rotation speed of the turbopump is reduced until an equilibrium between permissible power and gas friction is attained.

→ To avoid rotation speed fluctuations, Pfeiffer Vacuum recommends setting a somewhat lower frequency in rotation speed setting mode.

8.5 Run-up time

The run-up of the turbopump is time-monitored ex factory. There are various causes of prolonged run-up times, e.g.:

- Too high gas loads
- Leakage in the system
- The set value run-up time is too low

→ Eliminate any external and application-related causes.

→ Adjust the run-up time via parameter [P:700].

8.6 Adjusting the rotation speed switchpoint

The rotation speed switchpoint can be used for the message "Pump operational for the process". Overrunning or underrunning the active rotation speed switchpoint activates or deactivates a signal at the pre-configured output on the electronic drive unit and at the status parameter [P:302].

→ Adjust the parameter [P:701] to the desired value in %.

Signal output and status parameter [P:302] are based on the set value for rotation speed switchpoint 1 [P:701].

8.7 Rotation speed setting mode

The rotation speed setting mode reduces the rotation speed and hence the throughput of the turbopump. The pumping speed of the turbopump changes proportional to rotation speed. Standby mode is ineffective during rotation speed setting mode. The set rotation speed is adjusted by the set value in rotation speed setting mode [P:707]. The rotation speed switchpoint varies with the set rotation speed. Underrunning or overrunning the set value in rotation speed setting mode activates and deactivates the status signal [P:306] * respectively.



- *  → Adjust the parameter **[P:707]** to the desired value in %.
→ Parameter **[P:026]** = 1
→ Query parameters **[P:308]** .

8.8 Standby

Pfeiffer Vacuum recommends standby mode for the turbopump during process and production stops. When standby mode is active, the electronic drive unit reduces the rotation speed of the turbopump. Standby mode is ineffective during rotation speed setting mode. The factory setting for the set value in standby mode is 66.7 % of the nominal rotation speed. Underrunning or overrunning the set speed in standby mode activates or deactivates the status signal **[P:306]** *.

- *  → Adjust the parameter **[P:717]** to the desired value in %.
→ Parameter **[P:026]** = 0
→ Parameter **[P:002]** = 1
→ Query parameters **[P:308]** .

8.9 Operation mode backing pump

Operation of a connected backing pump via the electronic drive unit depends on the backing pump type.

- Connect the control lead of the relay box to the "remote" connection of the electronic drive unit using an adapter cable.
- Adjust the parameter **[P:025]** to the desired value.

8.9.1 Continuous operation

At the same time as "Pumping station on" the electronic drive unit sends a signal to the pin 11 to switch on the backing pump. This signal can also be used to control a fore-vacuum safety valve.

8.9.2 Intermittend operation (diaphragm pumps only)

Intermittend operation can extend the life expectancy of the membrane of a connected diaphragm pump. Either a diaphragm pump with built-in semiconductor relay or an inter-connected relay box with semiconductor relay is required for intermittend operation. The backing pump is switched on and off in dependence of the turbopump's power consumption. A relation to the supplied fore-vacuum pressure is derived from the power consumption. The switching off and switching on thresholds for the backing pump are adjustable. Fluctuations in the power consumption of idling turbopumps and type-dependent varying fore-vacuum pressures of the backing pumps require the switching thresholds to be set separately for the intermittend mode.

Pfeiffer Vacuum recommends the intermittend mode between 5 and 10 hPa. A pressure gauge and a dosing valve are required to set the switching thresholds.

- Switch on the vacuum system via the function "pumping station" and await the run-up.
- Generate a fore-vacuum pressure of 10 hPa by gas inlet via dosing valve.
- Read and note the parameter **[P:316]**.
- Adjust the switch on threshold backing pump via parameter **[P:711]** to the determined drive power for a fore-vacuum pressure of 10 hPa.
- Reduce the fore-vacuum pressure to 5 hPa.
- Read and note the parameter **[P:316]**.
- Adjust the switch off threshold backing pump via parameter **[P:710]** to the determined drive power for a fore-vacuum pressure of 5 hPa.



8.10 Operation with accessories

Depending on the configuration, various accessories can be connected to the turbopump and controlled via parameter of the electronic drive unit.

8.10.1 Air cooling/heating

- It is necessary to select the accessory device via parameters **[P:035]**.
- Display of the selected accessory via parameters **[P:335]**.

If air cooling is connected, it is immediately activated after switching on the pumping station with parameter **[P:010]**.



The ability to operate a connected housing heater depends on the rotation speed switchpoint via parameter **[P:701]**.

- Switch heating on or off with parameter **[P:001]**.

Exceeding or dropping below the rotation speed switchpoint controls the operation of the housing heater. The operating condition is represented by the symbol in the LCD display.

8.10.2 Vent modes

The turbopump can be vented only after the function "pumping station" has been switched off. Signals are sent to configured outputs with a fixed delay of 6 s. There are three options for operation with a venting valve connected.

- Enable venting via parameter **[P:012]**.
- Select the venting mode via parameter **[P:030]**.

Delayed venting

Start and venting time after "pumping station off" are configurable and depend on the rotation speed of the turbopump.

- Parameter **[P:030]** = 0
- Adjust the venting rotation speed in % of the nominal rotation speed via parameter **[P:720]**.
- Adjust the venting time in s via parameter **[P:721]**.

If the venting rotation speed is underrun, the venting valve will open for the set venting time. In the event of a power failure, venting will occur if the set venting rotation speed is underrun. In this case, the venting period depends on the residual energy delivered by the moving rotor. When power is restored, the venting process is interrupted.

No venting

No venting is performed during this operation mode.

- Parameter **[P:030]** = 1

Direct venting

Start and venting time are not configurable. Venting starts with a delay of 6 s after "pumping station off". When the function "pumping station" is switched on renewed, the venting valve closes automatically. In the event of a power failure, venting will occur if an anchored type-specific rotation speed is underrun. When power is restored, the venting process is interrupted.

- Parameter **[P:030]** = 2



8.11 Pressure measurement



Pressure measurement with the TCP

An exact pressure measurement is not possible with the TCP. This is particularly true with linear gauges in the lower pressure range.

→ Use suitable measuring instrument.

8.11.1 Displaying the gauge type

→ Select or enter parameter **[P:738] Gaugetype**.

Gauges with identical surge impedance are only recognized as a group (e.g. CMR?). Manual input of the exact gauge type is also possible via the parameter [P:738].

| Display example | Meaning |
|-----------------|--|
| TPR 2xx | Gauge TPR 280 connected |
| CMR ? | Gauge of the CMR Group connected, exact type not yet set |
| noGaug | No pressure gauge connected |

8.11.2 Displaying the active pressure value

→ Select parameter **[P:340] Pressure**.

| Display example | Meaning |
|-----------------|---|
| ——— mbar | No pressure gauge connected |
| < 5E-4mbar | Measuring range not reached (dependent on the device) |
| > 1E3mbar | Measuring range exceeded (dependent on the device) |
| 6.3E-9mbar | Valid pressure measurement |
| id fam mbar | Gauge type not yet identified; see [P:340] |
| Error | Error in pressure gauge |

8.12 Monitoring the thermal load

If threshold values are overrun, output signals from temperature sensors allow the pump to be brought to a safe condition. Depending on pump type, temperature threshold values for warnings and error messages are saved fixed in the electronic drive unit. For information purposes, various status queries are prepared in the parameter set.



8.13 Switching on/off the pump



Start pump by pressing "Pumping station ON/OFF" key

The "Pumping station" key only controls the parameter [P:010]. All components connected via the electronic drive unit will be activated or deactivated according to their configuration.

→ Ensure that the parameter [P:023] is also switched on for powering-up the turbopump.

8.13.1 Switching on

The function "pumping station" comprises turbopump operation with control of all connected accessories (e.g. backing pump).

→ Parameter [P:023] = 1

→ Parameter [P:010] = 1

After successfully completing a self-test, the electronic drive unit switches on the turbopump motor and all connected accessories as per their configuration.

When the pumping station is activated, the motor of the turbopump can be switched off and on via the function [P:023].

8.13.2 Switching off

→ Parameter [P:010] = 0

The electronic drive unit switches off the turbopump and activates preset accessory options (e.g. venting ON, backing pump OFF).



9 Pfeiffer Vacuum Protocol for "RS-485"

9.1 Telegram frame

The telegram frame of the Pfeiffer Vacuum protocol contains only ASCII code characters [32; 127], the exception being the end character of the message C_R . Basically, a master \square (e.g. a PC) sends a telegram, which is answered by a slave \circ (e.g. electronic drive unit or gauge).

| | | | | | | | | | | | | | | | | |
|---------|----|--|---|---|----|----|----|----|----|----|-----|----|----|----|----|-------|
| a2 | a1 | a0 | * | 0 | n2 | n1 | n0 | l1 | l0 | dn | ... | d0 | c2 | c1 | c0 | C_R |
| a2 - a0 | | Unit address for slave \circ - Individual address of the unit ["001";"255"] - Group address "9xx" for all identical units (no response) - global address "000" for all units on the bus (no response) | | | | | | | | | | | | | | |
| * | | Action (see p. 37, chap. 9.2) | | | | | | | | | | | | | | |
| n2 - n0 | | Pfeiffer Vacuum parameter numbers | | | | | | | | | | | | | | |
| l1 - l0 | | Data length dn ... d0 | | | | | | | | | | | | | | |
| dn - d0 | | Data in data type concerned (see p. 38, chap. 9.3) | | | | | | | | | | | | | | |
| c2 - c0 | | Checksum (sum of ASCII values of cells a2 to d0) modulo 256 | | | | | | | | | | | | | | |
| C_R | | carriage return (ASCII 13) | | | | | | | | | | | | | | |

9.2 Telegrams

Data request $\square \Rightarrow \circ ?$

| | | | | | | | | | | | | | | | |
|----|----|----|---|---|----|----|----|---|---|---|---|----|----|----|-------|
| a2 | a1 | a0 | 0 | 0 | n2 | n1 | n0 | 0 | 2 | = | ? | c2 | c1 | c0 | C_R |
|----|----|----|---|---|----|----|----|---|---|---|---|----|----|----|-------|

Control command $\square \Rightarrow \circ !$

| | | | | | | | | | | | | | | | | |
|----|----|----|---|---|----|----|----|----|----|----|-----|----|----|----|----|-------|
| a2 | a1 | a0 | 1 | 0 | n2 | n1 | n0 | l1 | l0 | dn | ... | d0 | c2 | c1 | c0 | C_R |
|----|----|----|---|---|----|----|----|----|----|----|-----|----|----|----|----|-------|

Data response / control command understood $\circ \Rightarrow \square \checkmark$

| | | | | | | | | | | | | | | | | |
|----|----|----|---|---|----|----|----|----|----|----|-----|----|----|----|----|-------|
| a2 | a1 | a0 | 1 | 0 | n2 | n1 | n0 | l1 | l0 | dn | ... | d0 | c2 | c1 | c0 | C_R |
|----|----|----|---|---|----|----|----|----|----|----|-----|----|----|----|----|-------|

Error message $\circ \Rightarrow \square *$

| | | | | | | | | | | | | | | | | | | | |
|----|----|----|---|---|----|----|----|---|---|---|---|---|---|---|---|----|----|----|-------|
| a2 | a1 | a0 | 1 | 0 | n2 | n1 | n0 | 0 | 6 | N | O | _ | D | E | F | c2 | c1 | c0 | C_R |
| | | | | | | | | | | _ | R | A | N | G | E | | | | |
| | | | | | | | | | | _ | L | O | G | I | C | | | | |

| | |
|--------|--|
| NO_DEF | The parameter n2 - n0 does not exist |
| _RANGE | Data dn - d0 are outside the permitted range |
| _LOGIC | Logic access violation |

9.2.1 Example 1

Data request

Actual rotation speed (parameter [P:309], device address slave: "123")

| | | | | | | | | | | | | | | | | |
|-------------------------------|----|----|----|----|----|----|----|----|----|----|----|----|----|----|----|-------|
| $\square \Rightarrow \circ ?$ | 1 | 2 | 3 | 0 | 0 | 3 | 0 | 9 | 0 | 2 | = | ? | 1 | 1 | 2 | C_R |
| ASCII | 49 | 50 | 51 | 48 | 48 | 51 | 48 | 57 | 48 | 50 | 61 | 63 | 49 | 49 | 50 | 13 |

Data response: 633 Hz

Actual rotation speed (parameter [P:309], device address slave: "123")

| | | | | | | | | | | | | | | | | | | | |
|--|----|----|----|----|----|----|----|----|----|----|----|----|----|----|----|----|----|----|-------|
| $\circ \Rightarrow \square \checkmark$ | 1 | 2 | 3 | 1 | 0 | 3 | 0 | 9 | 0 | 6 | 0 | 0 | 6 | 3 | 3 | 0 | 3 | 7 | C_R |
| ASCII | 49 | 50 | 51 | 49 | 48 | 51 | 48 | 57 | 48 | 54 | 48 | 48 | 54 | 51 | 51 | 48 | 51 | 55 | 13 |



9.2.2 Example 2

Control command

Switch on pumping station (parameter [P:010], device address slave: "042")

| | | | | | | | | | | | | | | | | | | | | |
|-------|----|----|----|----|----|----|----|----|----|----|----|----|----|----|----|----|----|----|----|----------------|
| ☐⇒○! | 0 | 4 | 2 | 1 | 0 | 0 | 1 | 0 | 0 | 6 | 1 | 1 | 1 | 1 | 1 | 1 | 0 | 2 | 0 | C _R |
| ASCII | 48 | 52 | 50 | 49 | 48 | 48 | 49 | 48 | 48 | 54 | 49 | 49 | 49 | 49 | 49 | 49 | 48 | 50 | 48 | 13 |

Control command understood

Switch on pumping station (parameter [P:010], device address slave: "042")

| | | | | | | | | | | | | | | | | | | | | |
|-------|----|----|----|----|----|----|----|----|----|----|----|----|----|----|----|----|----|----|----|----------------|
| ☐⇒○! | 0 | 4 | 2 | 1 | 0 | 0 | 1 | 0 | 0 | 6 | 1 | 1 | 1 | 1 | 1 | 1 | 0 | 2 | 0 | C _R |
| ASCII | 48 | 52 | 50 | 49 | 48 | 48 | 49 | 48 | 48 | 54 | 49 | 49 | 49 | 49 | 49 | 49 | 48 | 50 | 48 | 13 |

9.3 Applied data types

| Data type | Description | Size I1 - I0 | Example |
|-----------------|------------------------------|--------------|-----------------------|
| 0 - boolean_old | Boolean value (false / true) | 06 | 000000 / 111111 |
| 1 - u_integer | Positive integer number | 06 | 000000 to 999999 |
| 2 - u_real | Positive fixed point number | 06 | 001571 equal to 15.71 |
| 4 - string | String | 06 | TC_400 |
| 6 - boolean_new | Boolean value (false / true) | 01 | 0 / 1 |
| 7 - u_short_int | Positive integer number | 03 | 000 to 999 |
| 10 - u_expo_new | Positive exponential number | 06 | 100023 |
| 11 - string | String | 16 | BrezelBier&Wurst |



10 Malfunctions

10.1 General

Turbopump and electronic drive unit malfunctions always result in a warning or error message. In both cases, the electronic drive unit outputs an error code. Operating messages are generally displayed via the LEDs on the electronic drive unit. If an error occurs, the turbopump and connected devices will be switched off. The selected venting mode will be triggered after the preset delay.











| WARNING | |
|---|--|
| Automatic start-up after power failure or malfunction acknowledgement | |
| The function "pumping station" of the electronic drive unit remains active after power failure or errors that lead to shut down the pump or the system. The turbopump runs up automatically after power is restored or malfunction acknowledgement. | |
| <ul style="list-style-type: none"> → Switch off the function "pumping station" if necessary. → Provide safety measures against interference in the high vacuum flange while the turbopump is running. | |

10.2 Operation display via LED

10.2.1 Operation display via LED

The red LED (error status) and green LED (operating status) on the front panel of the TCP show the following states:

| LED | Symbol | LED status | Display | Meaning |
|--|--------|---------------------|---|--|
| Green  | | Off | — | currentless |
| | | On, flashing |  | "Pumping Station OFF", rotation speed $\leq 60 \text{ min}^{-1}$ |
| | | On, invers flashing |  | "Pumping Station ON", set rotation speed not attained |
| | | On, constantly |  | "Pumping Station ON", set rotation speed attained |
| | | On, blinking |  | "Pumping Station OFF", rotation speed $> 60 \text{ min}^{-1}$ |
| Red  | L | Off | — | no malfunction, no warning |
| | | On, flashing |  | Warning |
| | | On, constantly |  | Malfunction |

10.3 Error codes

Errors (** Error — **) always cause the connected peripheral devices to be switched off.

→ Eliminate error and reset by pressing key  .

Warnings (* Warning — *) are only displayed and do not cause components to be switched off.

| Error code | Problem | Possible causes | Remedy |
|------------|-----------------------|--|---|
| Err001 | Excess rotation speed | | <ul style="list-style-type: none"> ⇒ Contact Pfeiffer Vacuum Service ⇒ Only acknowledge for rotation speed $f = 0$ |
| Err002 | Overvoltage | – Incorrect mains input voltage | <ul style="list-style-type: none"> ⇒ Check mains input voltage ⇒ Only acknowledge for rotation speed $f = 0$ ⇒ Contact Pfeiffer Vacuum Service |
| Err006 | Run-up time error | <ul style="list-style-type: none"> – Run-up time threshold set too low – Gas flow in vacuum chamber through leaks or open valves – Still below rotation speed switchpoint run-up time expires | <ul style="list-style-type: none"> ⇒ Adjust run-up time to process conditions ⇒ Check vacuum chamber for leaks and closed valves ⇒ Check backup vacuum connection ⇒ Adjust rotation speed switchpoint |



| Error code | Problem | Possible causes | Remedy |
|------------|--|--|--|
| Err007 | Operating fluid low | – Operating fluid low | ⇒ Check operating fluid ⇒ Only acknowledge for rotation speed f = 0 ⇒ Can be acknowledged a max. of 5 times ⇒ Contact Pfeiffer Vacuum Service |
| Err015 | Group error message control unit | | ⇒ Mains OFF/ON at rotation speed f = 0 ⇒ Contact Pfeiffer Vacuum Service |
| Err021 | Electronic drive unit fails to identify pump | – Incorrect characteristic resistance – Pump not connected | ⇒ Check connections ⇒ Contact Pfeiffer Vacuum Service ⇒ Only acknowledge for rotation speed f = 0 |
| Err037 | Motor final stage or control error | | ⇒ Contact Pfeiffer Vacuum Service |
| Err040 | Memory expansion error | | ⇒ Contact Pfeiffer Vacuum Service |
| Err043 | Internal configuration error | – Parameter values stored incorrectly | ⇒ Contact Pfeiffer Vacuum Service |
| Err044 | Excess temperature electronics | – Insufficient cooling | ⇒ Improve cooling ⇒ Check deployment conditions |
| Err045 | Motor temperature protection | – Motor overheated – Run-up time in lower speed range (up to 90 Hz) > 6 min | ⇒ Improve cooling ⇒ Check fore-vacuum connection – Perform leak detection – Reduce fore-vacuum pressure |
| Err098 | Internal communication error | | ⇒ Contact Pfeiffer Vacuum Service |
| Err621 | Electronic drive unit fails to identify pump | – Incorrect characteristic resistance – Pump not connected | ⇒ Check connections ⇒ Contact Pfeiffer Vacuum Service ⇒ Only acknowledge for rotation speed f = 0 |
| Err699 | Error in TCP drive | | ⇒ Contact Pfeiffer Vacuum Service |
| Err777 | Nominal speed not confirmed | – Nominal speed not confirmed after replacing electronic drive unit | ⇒ Confirm nominal speed with [P:777] ⇒ Only acknowledge for rotation speed f = 0 |
| Wrn007 | Undervoltage/mains failure | – Mains failure | ⇒ Check power supply |
| Wrn046 | Data channel error | – Communication to parameter value memory faulty | ⇒ Contact Pfeiffer Vacuum Service |
| Wrn110 | Gauge warning | – Gauge faulty – Supply cable worked loose during operation | ⇒ Restart with gauge connected ⇒ Replace gauge ⇒ Install gauge correctly |

11 Accessories

| Designation | TCP 350 electronic drive unit |
|---|-------------------------------|
| Mains cable 230 V AC, CEE 7/7 to C13, 3 m | P 4564 309 ZA |
| Mains cable 115 V AC, NEMA 5-15 to C13, 3 m | P 4564 309 ZE |
| Mains cable 208 V AC, NEMA 6-15 to C13, 3 m | P 4564 309 ZF |
| Adapter cable, TCP 350 - backing pump relay box, M8 | PM 061 376 -T |
| Adapter cable, TCP 350 - backing pump relay box, M12 | PM 061 377 -T |
| Connection cable from TCP 350 to HiPace with 2 accessory ports M8, 3 m | PM 061 353 -T |
| Connection cable from TCP 350 to HiPace with 2 accessory ports M12, 3 m | PM 061 356 -T |





Declaration of conformity

We hereby declare that the product cited below satisfies all relevant provisions according to the following **EC directives**:

- **Electromagnetic Compatibility 2014/30/EU**
- **Low Voltage 2014/35/EU**

TCP 350

Harmonised standards and national standards and specifications which have been applied:

DIN EN 61000-3-2 : 2010
DIN EN 61000-3-3 : 2009
DIN EN 61010-1 : 2010
DIN EN 61326-1 : 2013
DIN EN 62061 : 2013
Semi F47-0200
Semi S2-0706

Signature:

Pfeiffer Vacuum GmbH
Berliner Straße 43
35614 Asslar
Germany

(Dr. Ulrich von Hülsen)
Managing Director

2017-03-31



VACUUM SOLUTIONS FROM A SINGLE SOURCE

Pfeiffer Vacuum stands for innovative and custom vacuum solutions worldwide, technological perfection, competent advice and reliable service.

COMPLETE RANGE OF PRODUCTS

From a single component to complex systems:

We are the only supplier of vacuum technology that provides a complete product portfolio.

COMPETENCE IN THEORY AND PRACTICE

Benefit from our know-how and our portfolio of training opportunities!

We support you with your plant layout and provide first-class on-site service worldwide.

Are you looking for a
perfect vacuum solution?
Please contact us:

Pfeiffer Vacuum GmbH
Headquarters • Germany
T +49 6441 802-0
info@pfeiffer-vacuum.de

www.pfeiffer-vacuum.com

PFEIFFER  **VACUUM**

